

Technical data sheet

Product features



Electric range with cabinet

Model	SAP Code	00008187
--------------	-----------------	----------



- Device type: Electric unit
- Power consumption of the zone 1 [kW]: 2,6
- Power consumption of the zone 2 [kW]: 2,6
- Protection of controls: IP24
- Material: AISI 304 top plate and cladding

SAP Code	00008187	Power electric [kW]	5.200
Net Width [mm]	400	Loading	400 V / 3N - 50 Hz
Net Depth [mm]	730	Number of zones	2
Net Height [mm]	900	Power consumption of the zone 1 [kW]	2,6
Net Weight [kg]	39.10	Power consumption of the zone 2 [kW]	2,6

Technical data sheet

Technical drawing



Electric range with cabinet

Model

SAP Code

00008187

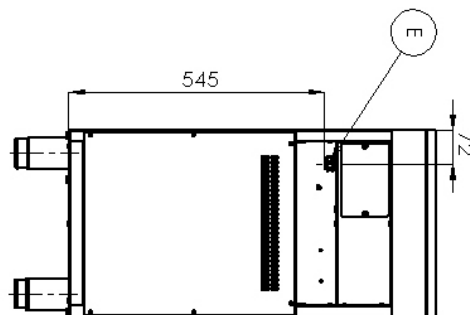
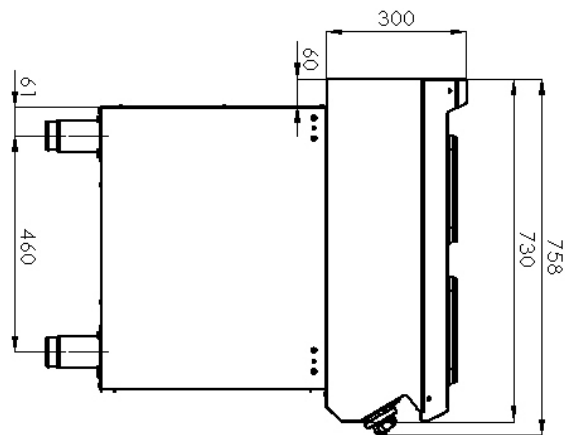
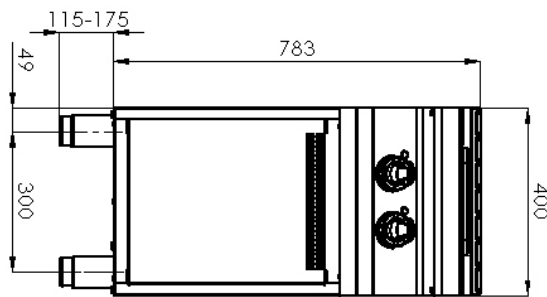

Technical data sheet

Technical parameters



Electric range with cabinet

Model

SAP Code

00008187

1. SAP Code:

00008187

2. Net Width [mm]:

400

3. Net Depth [mm]:

730

4. Net Height [mm]:

900

5. Net Weight [kg]:

39.10

6. Gross Width [mm]:

440

7. Gross depth [mm]:

800

8. Gross Height [mm]:

1080

9. Gross Weight [kg]:

45.50

10. Device type:

Electric unit

11. Construction type of device:

With substructure

12. Power electric [kW]:

5.200

13. Loading:

400 V / 3N - 50 Hz

14. Protection of controls:

IP24

15. Exterior color of the device:

Stainless steel

16. Material:

AISI 304 top plate and cladding

17. Indicators:

operation

18. Worktop type:

Molded - comfortable cleaning maintenance

19. Worktop material:

AISI 304

20. Worktop Thickness [mm]:

1.50

21. Number of zones:

2

22. Power consumption of the zone 1 [kW]:

2,6

23. Power consumption of the zone 2 [kW]:

2,6

24. Maximum device temperature [°C]:

400

25. Minimum device temperature [°C]:

50

26. Service accessibility:

Trough the frontal panel

27. Adjustable feet:

Yes

28. Number of burners/hot plates:

2

Technical data sheet

Technical parameters



Electric range with cabinet

Model	SAP Code	
		00008187

29. Type of electric cooking zones:

Squared